

INSTALLATION, OPERATION AND MAINTENANCE MANUAL



SERIES - 50 / 52 & 51 / 53

**Stafford Series –
50/52- 51/53
Butterfly Valves**

**INSTALLATION,
OPERATION AND
MAINTENANCE
MANUAL**

TECHNICAL DATA SHEET
T.D.S NO – 50/52
ISSUE DATE: JAN 2009



(Please read the entire instructions carefully before installation or servicing.)

Guarantee :

“Our liability in respect of any defect in or failure of the goods supplied or for any loss, injury or damage attributable onward is limited to making goods by replacement or repair defects which under proper use appear therein and arise solely from faulty materials and workmanship within a period of 18 calendar months after the original goods shall have been first shipped or 12 calendar months from the date of installation, whichever is earlier provided that such defective parts are returned without charge to our factory for examination. No other warranty is either expressed or implied.”

TABLE OF CONTENTS

Item	Description	Page no
1.	Introduction	2
2.	Technical Data	2
3.	Safety Precautions	2
4.	Transportation, Receiving and Storage	3
5.	Installation	3
6.	Operation of the Valve	4
7.	Maintenance	4
8.	Disassembly & Assembly Instructions (Series 50/52)	5
9.	Recommended Spare Parts (Series 50/52)	6
10.	Exploded View (Series 50/52)	7
11.	Disassembly & Assembly Instructions (Series 51/53)	8
12.	Recommended Spare Parts (Series 51/53)	8
13.	Exploded View (Series 51/53)	9
14.	Trouble Shooting	10

1 Introduction

1.1 Scope of the Manual.

The purpose of this manual is to ensure that the valves supplied are properly installed and maintained to give trouble free performance.

This manual covers Virgo's single piece body butterfly valves from 2" to 20" in both wafer and lug designs in 50 / 52 series and also 22" –36" in wafer & double flanged end design in series 51/53.

1.2 Marking.

Specifications of the valve are marked on the body or on name plate or both, prior to shipment. The identification marking generally consists of size of valve, pressure rating, body material, trim material and the date of manufacturing. (Ref to fig 1.1)

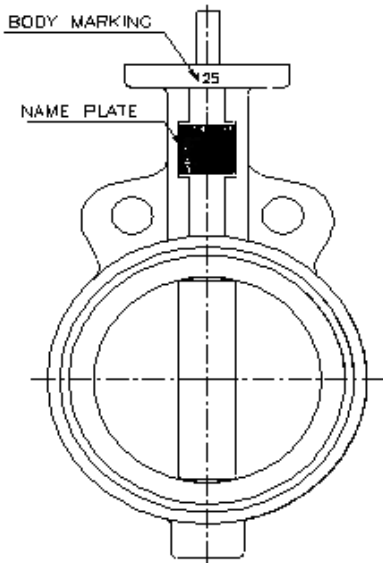

Fig 1.1 Valve Marking

2 Technical data

2.1 Pressure Rating

Construction :

Single piece body both in wafer and lug design.

Pressure Rating :

Valve Size	Rating
2" - 12"	175 PSI.
14" - 36"	150 PSI.
2" – 36"	50 PSI.

Seat Temperature Range.

Seat type	Temperature Range
EPDM	-13 ⁰ F (-25 ⁰ C) TO 248 ⁰ F (120 ⁰ C)
BUNA-N / Nitrile	-13 ⁰ F (-25 ⁰ C) TO 212 ⁰ F (100 ⁰ C)
Viton / FKM	-23 ⁰ F (-5 ⁰ C) TO 392 ⁰ F (200 ⁰ C)
Silicone	-58 ⁰ F (-50 ⁰ C) TO 356 ⁰ F (180 ⁰ C)

3 Safety Precautions.

3.1 Do not exceed the valve pressure / temperature rating limitations!

- Exceeding the pressure/temperature rating limitations marked on the valve may result in major damage or Personal injury. Users of these valves should ensure that the valve pressure / temperature is less than or equal to the rated pressure/temperatures. If required, end user should incorporate appropriate limiting/monitoring devices in the system for the safe operation of the valve.

3.2 Use the valve for specified application only!

- User to ensure that the valve is used only for the specified application as agreed between the manufacturer and the purchaser.

3.3 Follow the safety rules and regulations!

- User of the valve must be aware of all the safety rules and regulations related to a particular environment in which the valve is to be used.

3.4 Do not disassemble the valve or remove it from the pipeline while the valve is pressurized!

- Disassembling or removing a pressurized valve will result in uncontrolled pressure release. Always isolate the relevant part of the pipeline, release the pressure from the valve and remove the media before dismantling the valve.
- Be aware of the type of media involved. Protect people and the environment from any harmful or poisonous substances.
- Make sure that no dust, dirt can enter the pipeline during the valve maintenance.

3.5 When handling the valve or the valve package, bear in mind its weight!

- Never lift the valve or valve package by the handle, gear operator, actuator or hand wheel. Place the rope securely around the valve body while handling the valve. Refer to Fig No. 1.2

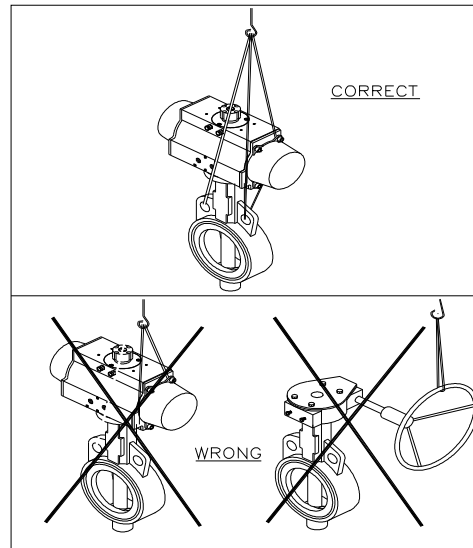

Fig 1.2 Lifting of the Valve

4 Transportation, Receiving and Storage.

- 4.1 Valves are being packed in cartons, boxes or pallets while shipping to the customer. Care should be taken to store them in a suitable place. We recommend storing the valves indoors in a dry and dust free atmosphere (Refer to figure 2.1). While unpacking the valves, check that the valves and any other accessories have not been damaged during transportation.

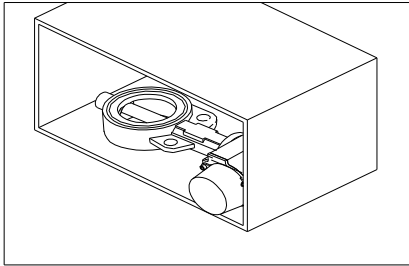

Fig 2.1 Storing the Valve.

- **Caution:**
Placing the valves directly on the ground or on a concrete floor should be avoided!

- 4.2 All wrapping and protection on the valves should not be removed until the valve is ready for installation. All valves are delivered with disc in 10° open position (Refer to figure 2.2).

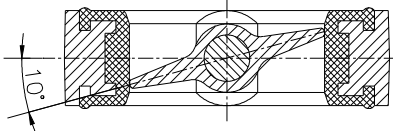

Fig 2.2 Disc in 10° open position

- 4.3 If the valves are stored for a long time, then all the valves should be cleaned and hydro / pneumatic tested before installation. Refer to General Arrangement drawing, which lists the appropriate testing standards, or consult the nearest branch office / factory for more information.
- 4.4 Valves are bi-directional and can be installed in either direction.
- 4.5 Lever or hand wheel of gear operator for respective valves are packed loosely and kept in the same box, in which the valve is packed (wherever applicable). When handling the valve either by hand or by mechanical means, special care should be taken not to damage the lever or gear operator. Lift the valve only as shown in fig 1.2. Lifting the valve from any other location may damage the valve components.

Note:

It is recommended to use ASTM A193 Gr.B7 fasteners for flange bolting.

5 Installation

- 5.1 When removing the valve from storage a careful check should be made to ensure that the valve has not been damaged during the storage period.
- 5.2 Valve open or close position is indicated on the notch plate for lever operated valves or on the top of the gear operator for gear operator operated valves.
- 5.3 Center valve, span body with bolts, but do not tighten. Slowly open disc to ensure that it clears adjacent pipe ID and leave at full open position. Tighten bolts in criss cross pattern.

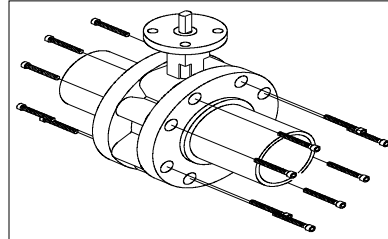

Fig 3.1 Lug Valve Installation.

- 5.4 For flange welding center valve with disc 10° open between flanges, span bolts, align this assembly in pipe and tack weld flanges to pipe. After tack welding, remove valve and finish welding.

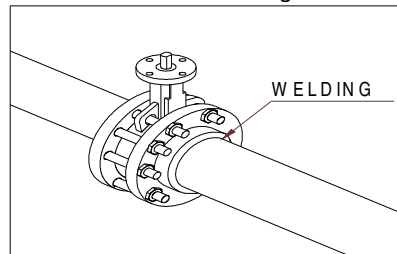

Fig 3.2

- 5.5 Valve should be checked for identification purpose and ensure that characteristics of valve matches to those specified for piping specifications, for the line where that is to be mounted. Nameplate instructions will give the necessary information.

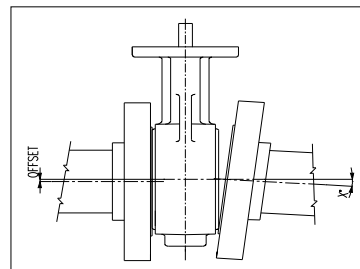

Fig 3.3 Valve Alignment.

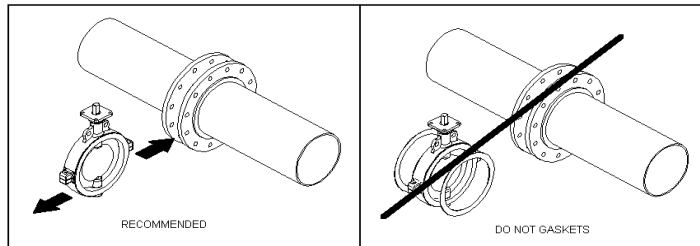

Fig 3.4: Installation of valve into pipe line.

Note: a) Do not attempt to correct the line misalignment by means of flange bolting Ref to fig 3.3.
 b) Do not use flange gaskets Ref to fig 3.4

6 Operation of the Valve.

- 6.1 For lever operated valves, the hand lever is either assembled with the valve or shipped loose depending upon the size of valve / hand lever.
- 6.2 For gear operated valves, **THE GEAR OPERATOR OPEN / CLOSE ADJUSTMENT HAS BEEN DONE PRIOR TO SHIPMENT AND MUST NOT BE CHANGED.** Rotation of hand wheel in the clockwise direction closes the valve and counter clockwise rotation opens it. (Looking from hand wheel end) The details of gear operator are shown in the fig. 4.1. The internal details/construction of gear operator may vary as per manufacturers standard.

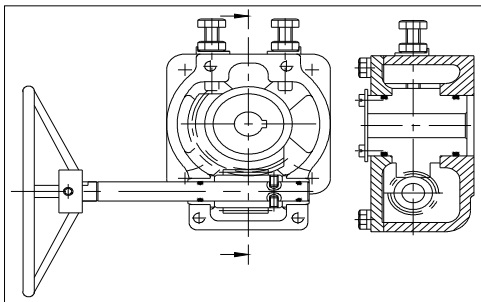

Fig 4.1 : Details of gear operator.

- 6.3 Virgo
- 6.4
- 6.5 Butterfly valve always close in a clockwise direction. Valve should always be rotated through 90° to the fully opened or fully closed position.
- 6.6 Valve should be opened and closed slowly to avoid hammering effect on the valve and pipeline.
- 6.7 Once the flushing is complete, valve should be operated 3-4 times and then kept in the fully open position.
- 6.8 If the valve is not operating to fully open or fully closed position, and/or leaking, do not apply excessive force to operate the valve. This can damage the seats or stem.

Caution:

- Apply gradual force on the handwheel of the gear operator and do not give impacts.
- Do not apply extra leverage (using pipe/bar), when the end stops of the gear operator are reached.

7 Maintenance.

Note:

Observe the safety precautions as outlined in section 3 before performing maintenance.

7.1 Preventive Maintenance.

- 7.1.1 In order to avoid valve failure during operation, all valves in a process plant should be periodically inspected thoroughly to detect the wear of disc, seats, seals and even body. It is recommended that on such occasions seats, seals and bushings should be replaced.
- 7.1.2 The type of process, fluids involved, working conditions and location of the valves in the process plants, will determine the frequency of periodic inspection / maintenance which in fact will be made at the time of partial or total shutdown of the plant. Preventive maintenance is absolutely essential as the failure due to lack of the same may cause an emergency shut down of the plant.
- 7.1.3 Section 8 describes the procedure for disassembly, repair and assembly of the valve. The procedure will be the same for a valve failing during operation due to lack of preventive maintenance.
- 7.1.4 Once a valve is repaired, it should undergo a complete set of tests to make sure that the valve is adequate for the original working conditions. Hydro/Pneumatic tests should be carried out as per the specifications relevant to the valve (Refer General Arrangement Drawing).

7.2 Lubrication of Worm Gear operator.

- 7.2.1 Worm gear operators are packed with grease. Normally the grease is suitable for -20°C (-4°F) to 80°C (176°F). For other applications, consult the nearest branch office / factory.
- 7.2.2 Grease should be changed as following. If operated frequently, after approx. 3 years. If operated rarely, after approx. 5 years.
- 7.2.3 Recommended Greases- Servogem EP2 (Extreme Pressure), Mobilux EP2, Valvoline EP2, Chevron EP2.

	WARNING Pipeline pressure can propel the loose flange bolts & flanges, and can cause personal injury or equipment damage. Relieve pipeline pressure before removing flange bolts and flanges.
---	---

	WARNING Moving Parts from accidental operation of powered (Pneumatically / Electrically) actuator can cause personal injury or equipment damage. Disconnect and lock power to actuator before servicing.
---	--

8 Disassembly and Assembly Instructions (50/52) :

8.1 Disassembly Instructions:

(Refer to exploded view No. 10.1)

Before disassembling, please ensure that all spare parts as detailed in Table 1 of Section 9, are available. For below mentioned procedure, the numbers in the bracket refer to the part numbers of the components as indicated in exploded view (fig no 10.1).

- In case the valve is in operation, release the pressure from the line.
- Rotate the valve stem (04) manually to keep the Valve in the half-open position. This will remove pressure in the pipeline.
- Always fully close valve before removing from line to avoid damage to disc
- Valve can be repaired by removing the entire valve from pipeline. Use mounting holes to lift the valve (Wherever applicable).

- 8.1.1 Unscrew the lever lock bolt (13). Lift the lever (14) by pressing the latch of the lever out of the stem (04) in case of hand lever operated valve.
- 8.1.2 Lift the gear operator (15) out of the stem (04) by removing the bolts in case of gear operated valve.

- 8.1.3 Remove the notch plate bolts (10) and remove the notch plate (09).
- 8.1.4 Remove the circlip (08) (fig 8.1) and pull the stem out with stem retainer ring (07).
- 8.1.5 Pull the disc (03) from the body (01) as shown in fig 8.2
- 8.1.6 Remove the stem bushing (06) and U cup stem seal (05) from the stem (04).
- 8.1.7 Compress the seat as shown and pull it out from the body (Refer to the fig 8.3).

Note: After the complete disassembly of the valve, all the components should be stored in a clean place to avoid damage.

8.2 Repair of Components.

- 8.2.1 The metallic parts should be cleaned.
- 8.2.2 To clean the seats and seals use a dry clean cloth.
- 8.2.3 After cleaning components examine for damaged parts. Ensure that there are no scoring marks on the metallic sealing surfaces. Check the seals for scratches / wear.
- 8.2.4 Replace the damaged parts. The parts such as seal, bushings are recommended to be replaced with new ones whenever the valve is dis-assembled: refer to Table 1 of Section – 9 for further details.

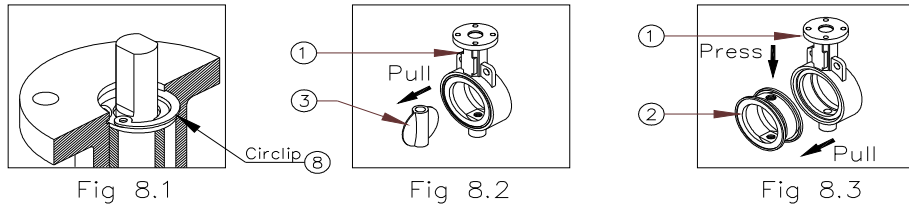

Disassembly of the Stem, Disc and Seat.

Note: When the gear operator or hand lever or actuator is re-assembled on the valve, it may be necessary to adjust gear operator or hand lever or actuator travel stops to ensure proper setting of the butterfly in the open and closed position

8.3 Assembly Instructions.

(Refer to exploded view No. 10.1)

8.3.1 VALVES OPERATING WITH LEVER.

- 8.3.1.1 Place the body (01) on a clean work surface.
- 8.3.1.2 Start assembly by pressing the seat as shown & pushing it into the valve body with seat stem holes aligned to the body stem holes as shown in the fig (8.4) and work the seat into the groove provided on the body.
- 8.3.1.3 Position the disc (02) as shown in fig (8.5) taking care that double D is at the bottom of the valve body. Special care must be taken not to damage the seat surface.

- 8.3.1.4 Insert the stem (04) into the body ensuring that double D of the stem aligns with double D of the disc.
- 8.3.1.5 Insert U cup seal (05), bushing (06), retainer ring (07) and then install the circlip (08) refer fig no 8.6.
- 8.3.1.6 Fit the notch plate (09) on the mounting flange with the notches in the first quadrant of the valve top plate with the stop tabs at the 12 O' clock and 3 O' clock position (fig 8.7).
- 8.3.1.7 Fit the lever (14) so that the lever fully engages in the notches when the lever latch is released and tighten the handle lock bolt (13).

8.3.1.8 Press the handle lever latch and position the disc so that the valve is in the fully closed position. Align the last notch on the notch plate at the 3-o clock position with the handle lever and tighten the notch plate screws.

8.3.1.9 Press the handle lever latch and position the disc so that the valve is in the fully open position and release the lever. The lever should line up with the last notch on the notch plate at the 12-o clock position.

8.3.2 VALVES OPERATING WITH GEAR OPERATOR.

(Refer Table 1 of Section –9 & Exploded View No. 10.1)

8.3.2.1 Follow the points from 8.3.1.1 to 8.3.1.5.

8.3.2.2 Rotate the valve disc to the fully open position.

8.3.2.3 Rotate the gear operator to the fully open position.

8.3.2.4 Line the valve stem with gear operator bore and slide the gear operator (15) onto the valve with the hand wheel (16) to the right of the valve name plate.

8.3.2.5 Position the gear operator so that the tapped holes in the bottom of the gear operator line up with the valve top mounting holes and install the mounting bolts.

8.3.2.6 Loosen the gear operator travel stops and rotate the handwheel until the valve is in the fully closed position. Tighten the travel stop on the right hand side of the gear operator.

8.3.2.7 Rotate the hand wheel until the valve is in fully open position. Tighten the travel stop on the left-hand side of the gear operator.

8.3.2.8 Make 2-3 cycles of the valve from fully open position to the fully closed position to make sure that the stops are set correctly.

9 Recommended Spares Kit.

- Before the start of the repair operations, we recommend that one set of spares as given in the table below should be available.
- For normal operation (2 years), we recommend one set of spares be available at site.

9.1 List of Recommended Spare Parts

Table no 1.

Part Name	Part No.	Qty. (Nos.)
Seat	2	01
Bushing	6	01
U cup seal	5	01
Circlip	8	01

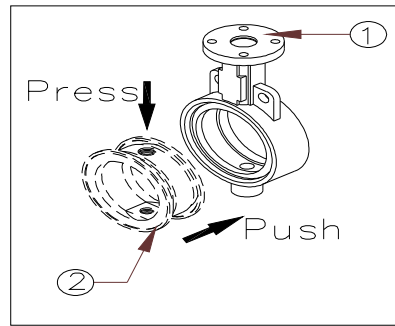

Fig 8.4

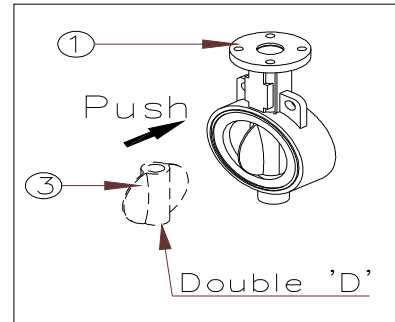

Fig 8.5

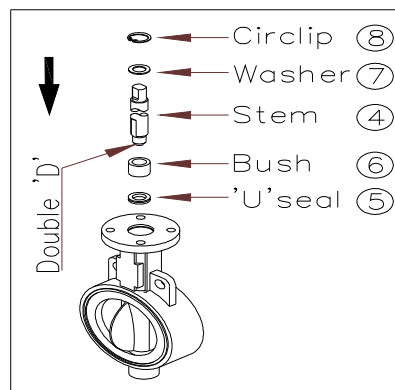

Fig 8.6

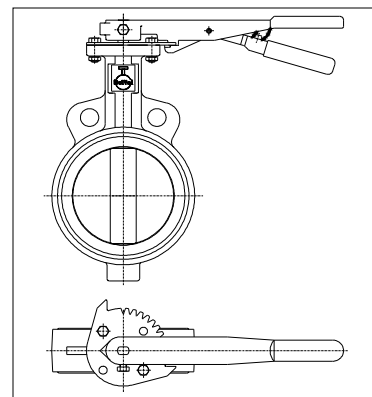
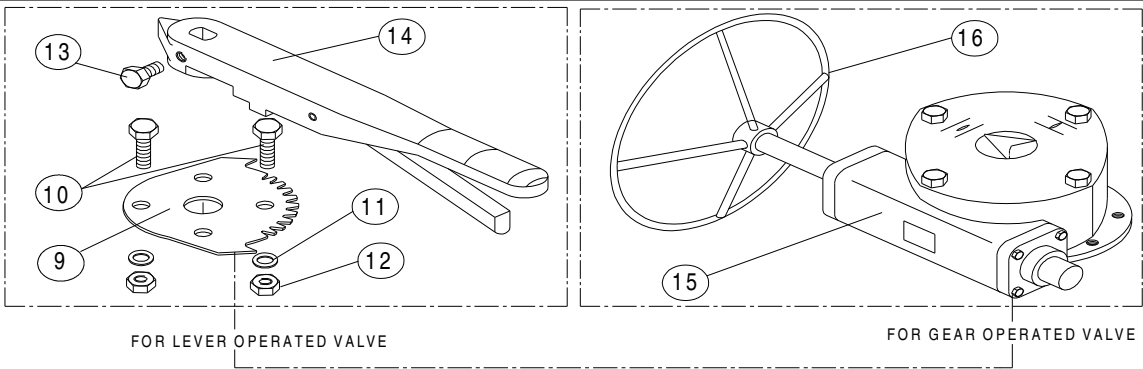
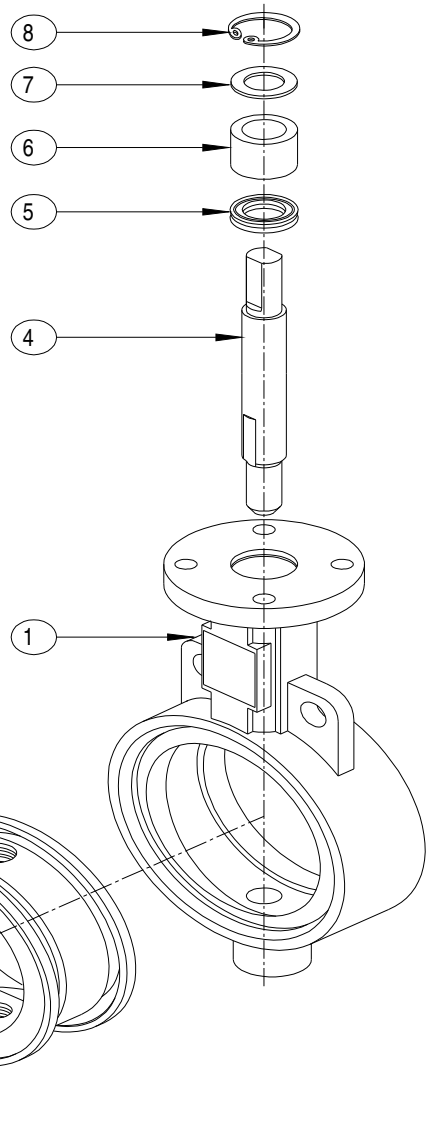

Fig 8.7 Notch plate position.

10. Explded View Exploded View Fig No: 10.1 (Series 50/52)



Sr.No.	DESCRIPTION	QTY.
1	BODY	01
2	SEAT	01
3	DISC	01
4	STEM	01
5	STEM SEAL(DOUBLE'U' CUP)	01
6	STEM BUSHING	01
7	STEM RETAINER	01
8	RETAINING CIRCLIP	01
9	NOTCH PLATE	01
10	HEX. HEADED SCREW	02
11	PLAIN WASHER	02
12	HEX. NUT	02
13	HAND LEVER LOCKING SCREW	01
14	HAND LEVER	01
15	GEAR OPERATOR	01
16	HANDWHEEL	01



11 Disassembly and Assembly Instructions (Series 51/53):

11.1 Disassembly Instructions:
(Refer to exploded view No. 10.1)

Before disassembling, please ensure that all spare parts as detailed in Table 1 of Section 12, are available.

Caution :

- In case the valve is in operation, release the pressure from the line.
- Rotate the valve stem (4) to keep the Valve in the half-open position. This will remove pressure in the pipeline.
- Always fully close valve before removing from line to avoid damage to disc.
- Valve can be repaired by removing the entire valve from pipeline. Use mounting holes to lift the valve (Wherever applicable).

- 11.1.1 Unscrew the Hex nut (19). Remove End washers (17) & pins (16).
- 11.1.2 Unscrew the hex. Headed screws of packing gland (8). Remove packing gland (7) and pull stem (4) out of valve body (1) with packing (5).
- 11.1.3 Pull Disc (3) out of valve body (1) as shown in fig. (8.2).
- 11.1.4 Compress the seat (2) as shown in fig. 8.3 and pull it out of valve body (1).
- 11.1.5 Unscrew the hex. headed screws of bottom plate (15). Remove bottom plate (13), gasket (12), thrust bearing (11) and spacer (10).
- 11.1.6 Remove top & bottom bearing (6).

11.2 Repair of Components :

- 11.2.1 All parts should be properly cleaned.
- 11.2.2 After cleaning components examine for damaged parts. Ensure that there are no scoring marks on the metallic sealing surfaces. Check the seals for scratches / wear.
- 11.2.3 Replace the damaged parts. The parts such as packing, gasket & 'O' rings are recommended to be replaced with new ones whenever the valve is dis-assembled: refer to Table 1 of Section – 12 for further details.

11.3 Assembly Instructions.
(Refer to exploded view No. 13.1)

- 11.3.1 Ensure that assembly place should be dry and clean.
- 11.3.2 Press the seat (2) as shown in fig.8.4 and push it into the valve body (1) with aligning body stem hole & seat hole.
- 11.3.3 Insert top bearing (6) through stem hole on valve body.

- 11.3.4 Insert bottom bearing (6), spacer (10) and thrust bearing (11) through bottom stem hole on valve body.
- 11.3.5 Mount bottom plate (13) with gasket (12) and tighten he hex headed screw (15) with washer (14).
- 11.3.6 Position disc (2) as shown in fig.8.5 and push it into valve body (1). Special care must be taken not to damage the seat surface.
- 11.3.7 Insert stem (4) into valve body (1) through disc (3). Ensuring that pin holes on disc and stem matches properly.
- 11.3.8 Mount end washer (17) on disc pin hole, insert pins (16) through disc (3) and stem (4) then mount end washers (17) from other side and tight by hex nut (19).
- 11.3.9 Insert packing (5), packing gland (7) and tighten gland by using hex headed screw (8) & washer (9).

12 Recommended Spares Kit :

- Before start of repair operations, we recommend that one set of spares as given in the table below should be available.
- For normal operation (2 years), we recommend one set of spare be available at site.

12.1 List of Recommended Spare Parts :

Table no. 1		
Part Name	Part No.	Qty.(Nos.)
Seat	2	01
Packing	5	01
Bearing	6	02
Thrust Bearing	11	01
Gasket	12	01
'O' Ring	18	04

13. Exploded View :
Exploded View Fig No. 13.1 (Series 51/53)

Sr.No.	DESCRIPTION	QTY	
		51	53
1	BODY	1	1
2	SEAT	1	1
3	DISC	1	1
4	STEM	1	1
5	PACKING	1	1
6	BEARING	2	2
7	PACKING GLAND	-	1
8	HEX. HD. SCREW	-	2
9	WASHER	-	2
10	SPACER	1	1
11	THRUST BEARING	1	1
12	GASKET	1	1
13	BOTTOM PLATE	1	1
14	WASHER	4	4
15	HEX. HD. SCREW	4	4
16	PIN	2	2
17	END WASHER	4	4
18	'O' RING	4	4
19	HEX. NUT	4	4
20	KEY	1	1
21	SOC. HD. SCREW	1	1
22	NAME PLATE	1	1

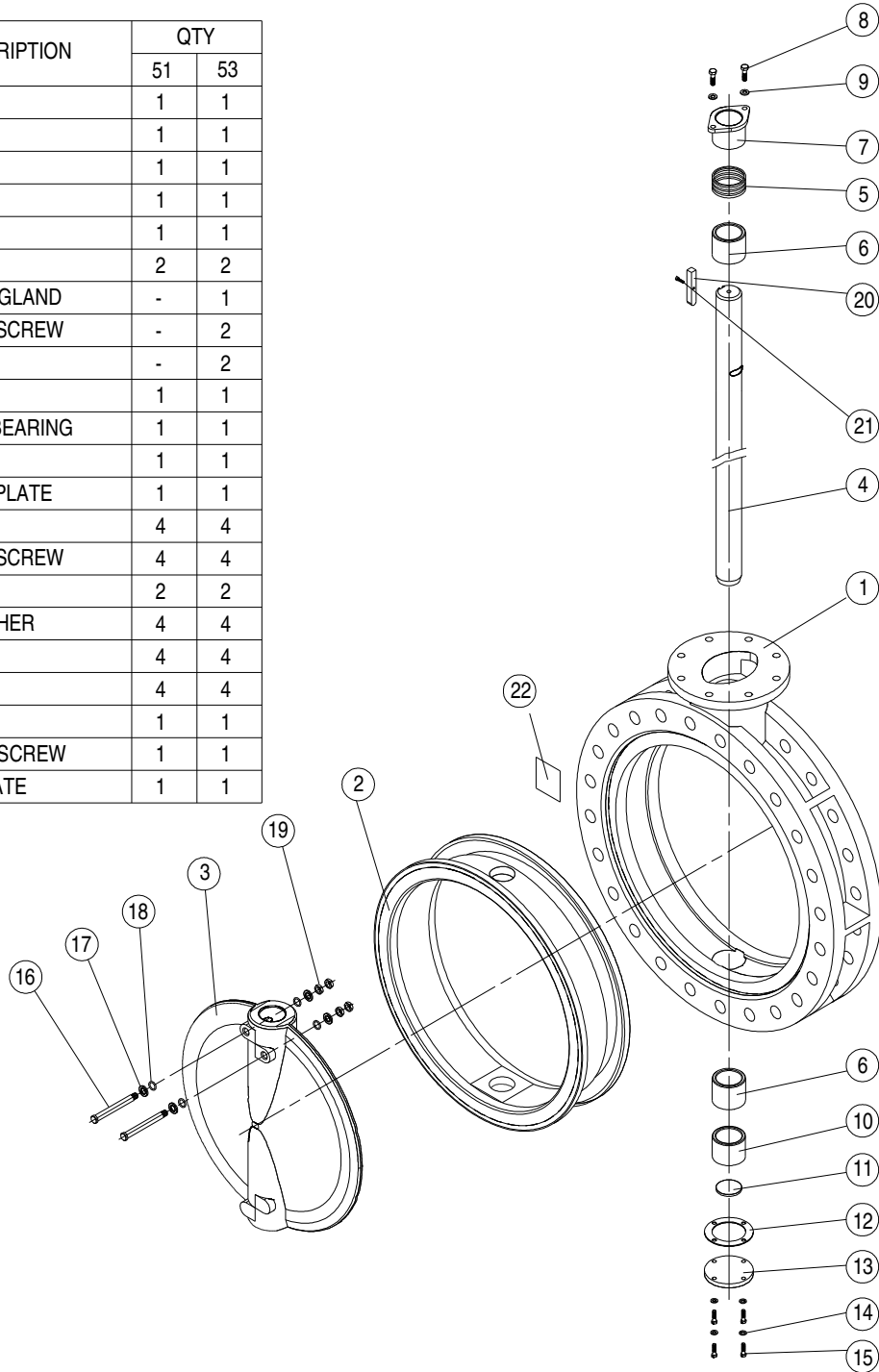

Troubleshooting:

Symptom	Cause	Corrective Action
Stem Leaks	Stem seal in seat is leaking	Replace stem sealing as described in disassembly & assembly.
Valve leaks at closed position	Seat is worn or damaged	Replace seat as described in disassembly & assembly.
	Disc edge is worn or damaged.	Consult factory for potential application problem.

	STAFFORD CONTROLS LIMITED # 319 , SIDCO Industrial Estate, Ambattur ,Chennai – 600 098, India Phone : (044) 26241719; Fax : (044) 26258319 E-mail : sales@staffordvalves.com www.staffordvalves.com www.staffordcontrols.com	
	T.D.S No : 50/52	Rev No: 0